

# Multilin™ T60

## TRANSFORMER PROTECTION SYSTEM

Fully featured, multiple winding  
transformer protection



### KEY BENEFITS

- Secure high-speed protection for transformers, compliant with IEEE C37.91
- Complete IEC 61850 Process Bus solution providing resource optimization and minimizing total P&C life cycle costs
- Improved security for transformer energization and inrush provided through a superior Adaptive 2nd Harmonic Restraint algorithm
- Ambient temperature monitoring with alarming when outside temperature exceeds upper thresholds
- Integrated transformer thermal monitoring for asset management maintenance optimization
- Sensitive ground fault protection provides low impedance differential protection down to 5% of the winding to limit transformer damage
- Robust network security enabling Critical Infrastructure Protection through user command logging, and dual permission access control
- Advanced automation capabilities for providing customized protection and control solutions
- Advanced fault and disturbance recording, including internal relay operating signals thus eliminating the need for redundant recording devices
- Reduced relay to relay wiring and associated installation costs through high-speed inter-relay communications

### APPLICATIONS

- Transformer asset monitoring using Hottest Spot, Loss-of-Life and Aging Factor
- Applicable for transformers with windings in a ring bus or breaker-and-a-half configuration
- Reliable and secure protection for three-phase transformers, autotransformers, reactors, split phase and phase angle regulating transformers
- Stand-alone or component in automated substation control system

### FEATURES

#### Protection and Control

- Dual slope, dual breakpoint differential restraint characteristic restrained and unrestrained differential
- 2nd harmonic inrush and overexcitation inhibit
- Transformer overexcitation and thermal overload protection
- Restricted ground fault
- Loss-of-Life, Aging Factor, Hottest Spot
- 3 zone back-up distance protection with power swing detection and load encroachment function
- Synchrocheck

#### Communications

- Networking interfaces - 100Mbit Fiber Optic Ethernet, RS485, RS232, RS422, G.703, C37.94
- Multiple Protocols - IEC 61850, DNP 3.0 Level 2, Modbus RTU, Modbus TCP/IP, IEC 60870-5-104, Ethernet Global Data (EGD)
- Direct I/O - secure, high-speed exchange of data between URs for Direct Transfer Trip applications
- Embedded Managed Ethernet Switch with 4 - 100 Mbit Fiber optic ports and 2 copper ports

#### IEC 61850 Process Bus Interface

- Robust communications with up to 8 HardFiber Bricks
- Seamless integration with existing T60 functions
- Redundant architecture for dependability and security

#### Monitoring and Metering

- Metering - current, voltage, power, energy, frequency, temperature, transformer monitoring
- P & M Class synchrophasors of voltage, current and sequence components - 1 to 120 frames/sec
- Oscillography - analog and digital at 64 samples/cycle
- Event Recorder - 1024 time tagged events with 0.5ms scan of digital inputs
- Data Logger - 16 channels with sampling rate up to 1 sample / cycle
- Security Audit Trail for tracking changes to T60 configuration

#### EnerVista™ Software

- Graphical Logic Designer and Logic Monitor to simplify designing and testing procedures
- Document and software archiving toolset to ensure reference material and device utilities are up-to-date
- EnerVista™ Integrator providing easy integration of data in the T60 into new or existing monitoring and control systems

## Protection and Control

The T60 Transformer Protection System is a comprehensive three-phase transformer relay designed to protect medium and large power transformers. The T60 provides automatic or user definable magnitude reference winding selection for CT ratio matching, and performs automatic phase shift compensation for all types of transformer winding connections. The T60 algorithm allows the user to enable removal of the zero-sequence current even for delta connected transformer windings, facilitating transformers with a variety of grounding configurations.

As part of the Universal Relay (UR) Family, the T60 provides superior protection and control that includes:

### Percent Differential Protection

The T60 provides enhanced security by including both restrained and unrestrained (instantaneous) differential protection. The Percent Differential element is based on a configurable dual-breakpoint / dual slope differential restraint characteristic with inrush and overexcitation inhibits. The maximum winding current is used as a restraining signal for better through fault stability under CT saturation conditions.

The percent characteristic allows the element to account for both DC and AC saturation of the current transformers

### Inrush Inhibit

The 2nd harmonic inhibit function is selectable in order to cover energization

## T60 - Protection, Metering, Monitoring and Control

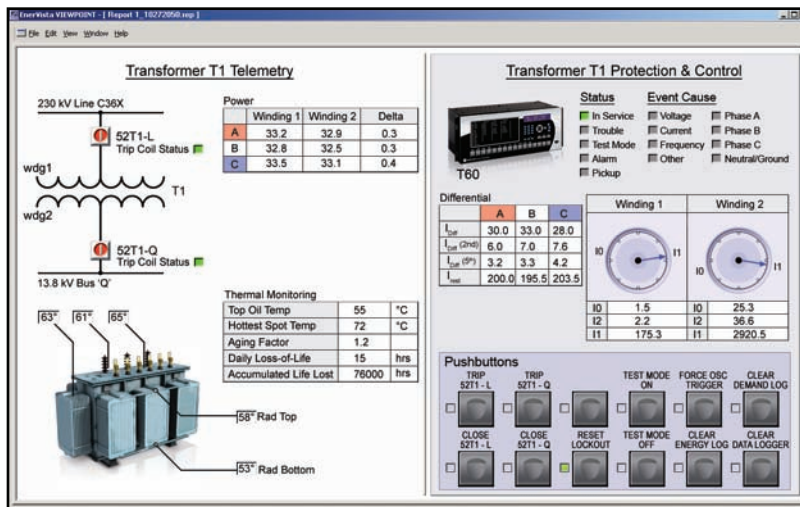

The T60 is the single point for protection, control, metering, and monitoring in one integrated device that can easily be connected directly into DCS or SCADA monitoring and control systems like Viewpoint Monitoring as shown.

of different type transformers, can be set to either traditional or adaptive mode. The adaptive mode maximizes dependability on internal faults and ensures security during inrush conditions even with weak second harmonics. It reduces the sensitivity of magnitude comparison by biasing towards security based on angular relationship. Dependability is maintained by applying the restraint signal only for a period of time dependent on the magnitude ratio.

### Overexcitation Inhibit

An increase in transformer voltage or decrease in system frequency may result in overexcitation of the transformer. It is often desirable to prevent operation of

the percent differential element in these cases therefore a fifth harmonic inhibit is integrated into the percent differential element to cater for overexcitation conditions resulting from an increased V/Hz ratio.

### Unrestrained Differential

An unrestrained differential element is provided for fast tripping on heavy internal faults to limit catastrophic damage to the transformer and minimize risks to the remainder of the power system.

### Restricted Ground Fault (RGF)

RGF (also known as zero sequence differential) extends protection coverage to the neutral point of wye-connected

## Functional Block Diagram

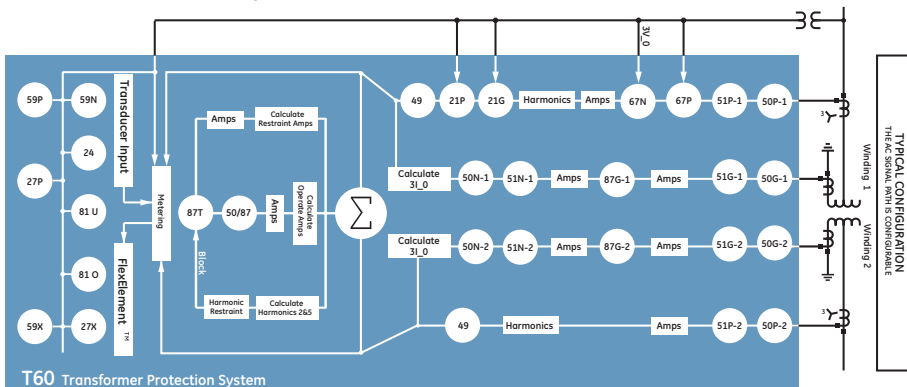

## ANSI Device Numbers & Functions

Device Number	Function
21P	Phase Distance
21G	Ground Distance
24	Volts Per Hertz
27	Phase Undervoltage
27X	Auxiliary Undervoltage
49	Thermal Overload
50G	Ground Instantaneous Overcurrent
50N	Neutral Instantaneous Overcurrent
50P	Phase Instantaneous Overcurrent
50/87	Instantaneous Differential Overcurrent
51G	Ground Time Overcurrent
51N	Neutral Time Overcurrent
51P	Phase Time Overcurrent
59N	Neutral Overvoltage
59P	Phase Overvoltage
59C	Auxiliary Overvoltage
67N	Neutral Directional Overcurrent
67P	Phase Directional Overcurrent
81O	Overfrequency
81U	Underfrequency
87G	Restricted Ground Fault
87T	Transformer Differential

## Differential vs. Restraint Characteristic ( $I_d$ vs. $I_r$ )

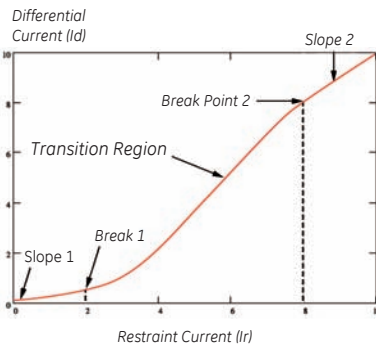

The settings for the dual-slope, dual-breakpoint characteristic provides higher flexibility for shaping up the characteristic and achieve better sensitivity and security.

windings where fault currents may be below the pickup of the main transformer differential elements. The low-impedance RGF protection provided in the T60 uses an optimized adaptive restraint signal that provides security for external fault conditions that may cause CT saturation while still maintaining sensitivity for internal faults.

### Distance

Separate high-speed phase and ground distance elements are provided in T60 as a back-up protection. T60 comes with three phase and ground distance quad and mho distance elements. The phase distance elements come with built-in in-zone transformer compensation. The T60 also provides a load encroachment element, which supervises the distance elements under heavy resistive loading conditions.

### Overcurrent Functions

T60 provides thermal overload, time and instantaneous overcurrent elements for phase, neutral, ground, phase and neutral directional. All of them can run in parallel with primary differential protection or can be programmed to provide primary protection under conditions when other protections elements are blocked.

### User-Definable Protection Functions

Sixteen user-definable protection functions (FlexElements™) can be programmed to respond to any quantity measured or computed by the relay (phase, ground and sequence currents and voltages, power, frequency, power factor, etc.) These elements respond to variations in

its input signal. Applications could include: overvoltage, overpower, low power factor, temperature differential, and more.

## IEC 61850 Process Bus

The IEC 61850 Process Bus module is designed to interface with the Multilin HardFiber System, allowing bi-directional IEC 61850 fiber optic communications. The HardFiber System is designed to integrate seamlessly with the existing Universal Relay applications, including protection functions, FlexLogic, metering and communications.

The Multilin HardFiber System offers the following benefits:

- Communicates using open standard IEC 61850 messaging
- Drastically reduces P&C design, installation and testing labor by eliminating individual copper terminations
- Integrates with existing T60's by replacing traditional CT/VT inputs with IEC 61850 Process Bus module
- Does not introduce new Cyber Security concerns

Visit the HardFiber System product page on the GE Digital Energy web site for more details.

## Advanced Automation

The T60 incorporates advanced automation features including powerful FlexLogic™ programmable logic, communication, and

SCADA capabilities that far surpass what is found in the average transformer relay. The T60 integrates seamlessly with other UR relays for complete system protection.

### FlexLogic™

FlexLogic™ is the powerful UR-platform programming logic engine that provides the ability of creating customized protection and control schemes thereby minimizing the need, and the associated costs, of auxiliary components and wiring.

Using FlexLogic™, the T60 can be programmed to provide required tripping logic along with custom scheme logic for line phase comparison (including interlocking with external synchronizers), transfer tripping schemes for remote breakers and dynamic setting group changes.

### Scalable Hardware

The T60 is available with a multitude of I/O configurations to suit the most demanding application needs. The expandable modular design allows for easy configuration and future upgrades.

- Multiple CT/VT configurations allow for implementation of many differential schemes, including concurrent split-phase and differential protection
- Types of digital outputs include trip-rated Form-A and Solid State Relay (SSR) mechanically latching, and Form-C outputs
- RTDs and DCmA inputs are available to monitor equipment parameters such as temperature & pressure

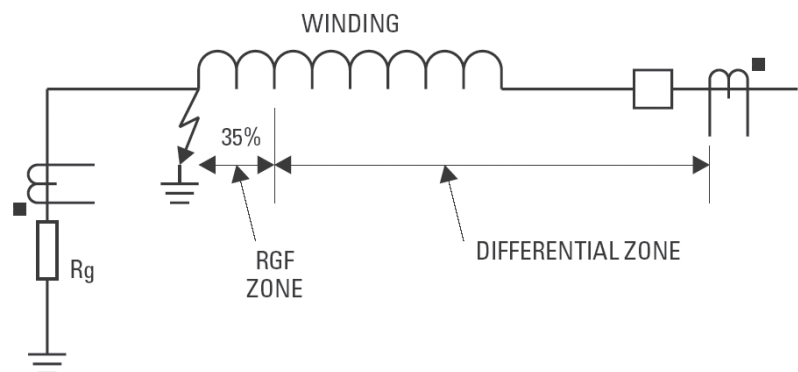

Faults close to the neutral point of a wye-connected winding does not generate adequate fault current for differential element to pick up. Restricted Ground Fault protection provides sensitive ground fault detection for low-magnitude fault currents.

### FlexLogic™ Designer

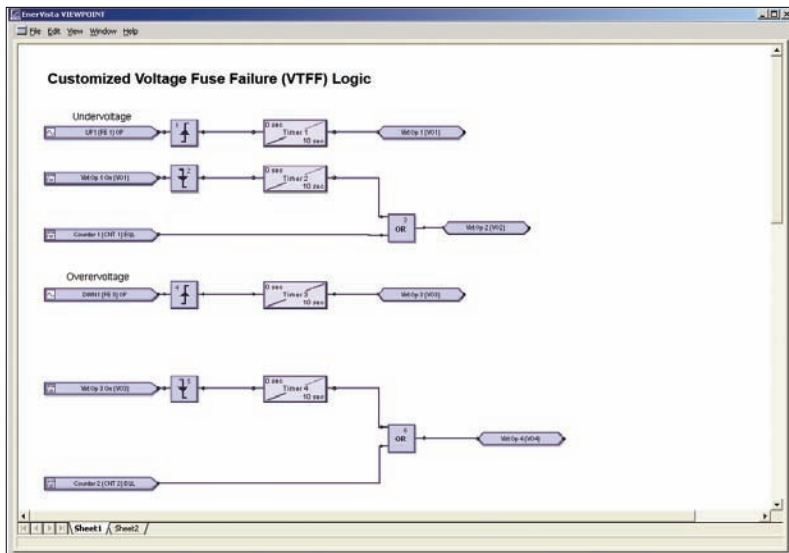

Flexlogic™ allows for customizing the T60 to operate and control the breakers and other auxiliary devices needed to fit most generator protection schemes and applications.

- Sequence of Event (SOE):  
1024 time stamped events
- Oscillography:  
64 digital & up to 40 Analog channels
- Data Logger, disturbance recording:  
16 channels up to 1 sample / cycle / channel
- Fault Reports:  
Powerful summary report of pre-fault and fault values
- Extensive breaker info (continuous coil monitor, arcing current, operating time, operation counter for assert management)

The very high sampling rates and large amount of storage space available for data recording in the T60 can eliminate the need for installing costly standalone recording equipment.

### Monitoring and Metering

The T60 includes high accuracy metering and recording for all AC signals. Voltage, current, and power metering are built into the relay as a standard feature. Current and voltage parameters are available as total RMS magnitude, and as fundamental frequency magnitude and angle. Also, harmonic measurements for voltage and current up to 25th for power quality applications.

T60 can monitor, calculate and log hottest-spot temperature, aging factor and lost of life data over a long period. These data

combined with economic analysis, allows criteria to be developed regarding the best time at which to replace a power transformer due to load growth, i.e. to minimize the cost without significantly increasing the risk.

### Fault and Disturbance Recording

The advanced disturbance and event recording features within the T60 can significantly reduce the time needed for postmortem analysis of power system events and creation of regulatory reports. Recording functions include:

### Temperature Monitoring – RTD Module Option 5C

The T60 RTD option provides 8 programmable RTD inputs per module that are used for temperature monitoring. Each RTD input has 2 operational levels: alarm and trip. The T60 supports RTD trip voting and provides open RTD failure alarming. Alternatively, a remote RTD module “RRTD”, which supports 12 RTD inputs, can also be used with the T60 for temperature monitoring. The RRTD provides cost savings when compared to traditional RTD wiring.

### Advanced Device Health Diagnostics

The T60 performs comprehensive device health diagnostic tests during startup and continuously at runtime to test its own major functions and critical hardware. These diagnostic tests monitor for conditions that could impact security and availability of protection, and present device status via SCADA communications and front panel display. Providing continuous monitoring and early detection of possible issues helps improve system uptime.

- Comprehensive device health diagnostic performed during startup
- Monitors the CT/VT input circuitry to validate the integrity of all signals

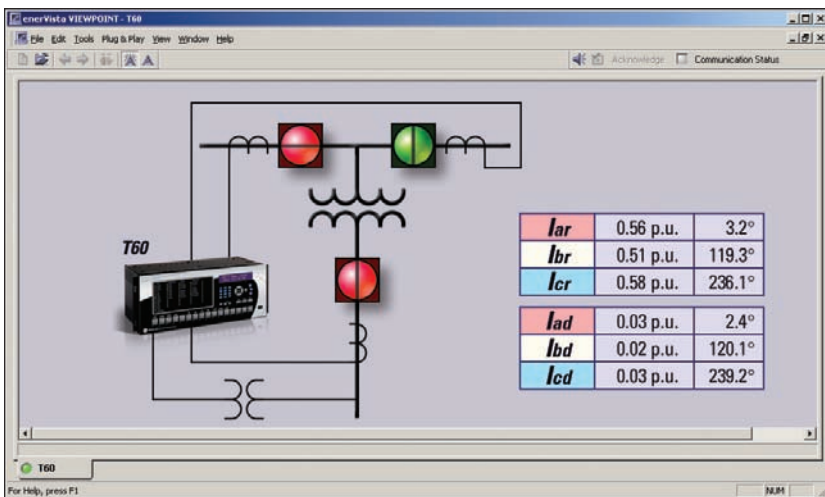

Multi-Breaker application example



- Input, outputs, trip circuits and analog channels are continuously monitored for accuracy and performance

### Advance Asset monitoring

The T60 has advance functions that rise an alarm or trip the scheme when an internal condition in the power transformer, such as temperature or insulation aging, or breakers that could lead to a fault. These elements are:

- Hottest-spot Temperature: element provides a mechanism for detecting abnormal winding hottest-spot temperatures inside the transformer.
- Aging Factor: The Aging Factor element detects transformer aging in per-unit normal insulation aging.
- Loss of Life: The Loss of Life element detects the accumulated total consumed transformer life.
- Breaker Arching Current: This element calculates an estimate of the per-phase deterioration on the breaker contacts by measuring and integrating the current squared passing through the breaker contacts as an arc.

These elements allow to user to optimize maintenance routines on the power transformer and breakers.

## Communications

The T60 provides advanced communications technologies for remote data and engineering access, making it the most advanced and flexible transformer protection relay to use and integrate into new and existing infrastructures. Direct support for fiber optic Ethernet provides high-bandwidth communications allowing for low-latency controls and high-speed file transfers of relay fault and event record information. The available redundant Ethernet option and the embedded managed Ethernet switch provide the means of creating fault tolerant communication architectures in an easy, cost-effective manner without the need for intermediary communication hardware.

The T60 supports the most popular industry standard protocols enabling easy, direct integration into DCS and SCADA systems.

- IEC 61850
- DNP3.0
- Ethernet Global Data (EGD)
- IEC 60870-5-104
- Modbus RTU, Modbus TCP/IP

## Interoperability with Embedded IEC 61850

Use the T60 with integrated IEC 61850 to lower costs associated with substation protection, control and automation. GE Energy's leadership in IEC 61850 comes from thousands of installed devices and follows on seven years of development experience with UCA 2.0.

- Replace expensive copper wiring between devices with direct transfer of data using GOOSE messaging
- Configure systems based on IEC 61850 and also monitor and troubleshoot them in real-time with EnerVista™ Viewpoint Engineer
- Integrate Multilin IEDs and generic IEC 61850-compliant devices seamlessly in EnerVista™ Viewpoint Monitoring

## Direct I/O Messaging

Direct I/O allows for sharing of high-speed digital information between multiple UR relays via direct back-to-back connections or multiplexed through a standard DS0 multiplexer channel bank. Regardless of the connection method, Direct I/O provides continuous real-time channel monitoring that supplies diagnostics information on channel health.

## Power System Troubleshooting

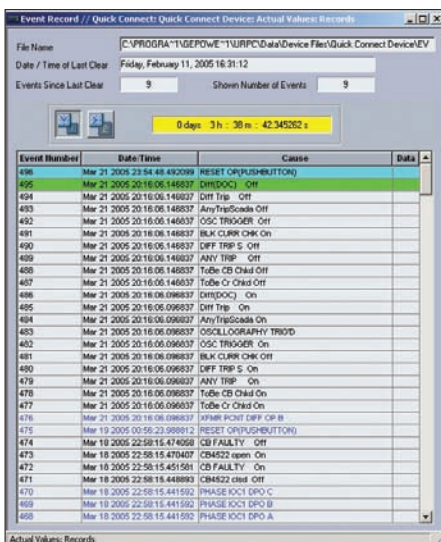

Record the operation of the internal T60 elements and external connected devices with 1ms time-stamped accuracy to identify the Sequence of Operation of station devices during transformer faults and disturbances.

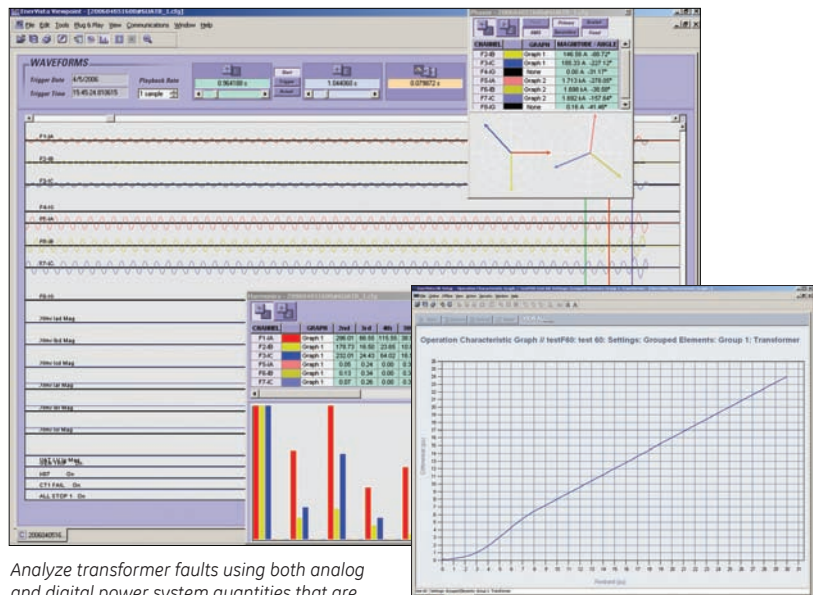

Analyze transformer faults using both analog and digital power system quantities that are measured and recorded up to a rate of 64 samples per cycle.

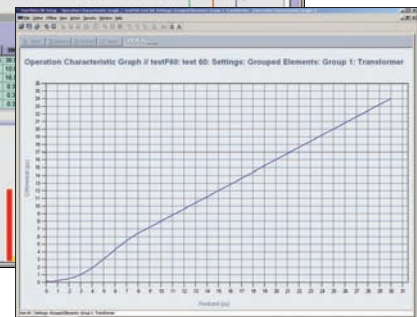

Visualization of differential characteristics allows to verify settings and trouble shoot operations.

Direct I/O provides superior relay-to-relay communications that can be used in advanced interlocking, generation rejection and other special protection schemes.

- Communication with up to 16 UR relays in single or redundant rings rather than simplistic point-to-point configurations
- Connect to standard DSO channel banks through standard RS422, G.703 or IEEE C37.94 interfaces or via direct fiber optic connections
- Built-in continuous loop and channel monitoring provides real-time diagnostics of your communication channels – no external or handheld tester required

### Multi-Language

The T60 supports English, French, Russian, Chinese and Turkish Languages on the front panel, EnerVista™ setup software, and product manual. Easily switch between English and an additional language on the local displays without uploading new firmware.

### EnerVista™ Software

The EnerVista™ Suite is an industry-leading set of software programs that simplifies every aspect of using the T60 relay. The EnerVista™ suite provides all the tools to monitor the status of the transformer, maintain the relay, and integrate information measured by the T60 into DCS or SCADA monitoring systems. Convenient COMTRADE and Sequence of Events viewers are an integral part of the UR Setup software included with every UR relay, to carry out postmortem event analysis to ensure proper protection system operation.

### EnerVista™ Launchpad

EnerVista™ Launchpad is a powerful software package that provides users with all of the setup and support tools needed for configuring and maintaining Multilin products. The setup software within Launchpad allows configuring devices in real-time by communicating using serial, Ethernet, or modem connections, or offline by creating setting files to be sent to devices at a later time.

Included in Launchpad is a document archiving and management system that ensures critical documentation is up-to-date and available when needed. Documents made available include:

- Manuals
- Application Notes & support documents
- Guideform Specifications
- Brochures
- Wiring Diagrams
- FAQ's
- Service Bulletins

### Viewpoint Monitoring

Viewpoint Monitoring is a simple-to-use and full-featured monitoring and data recording software package for small systems. Viewpoint Monitoring provides a complete HMI package with the following functionality:

- Plug-&-Play Device Monitoring
- System Single-Line Monitoring & Control
- Annunciator Alarm Screens
- Trending Reports
- Automatic Event Retrieval
- Automatic Waveform Retrieval

### Viewpoint Engineer

Viewpoint Engineer is a set of powerful tools that will allow you to configure and test UR relays at a system level in an easy-to-use graphical drag-and-drop environment. Viewpoint Engineer provides the following configuration and commissioning utilities:

- Graphical Logic Designer
- Graphical System Designer
- Graphical Logic Monitor
- Graphical System Monitor
- IEC 61850 Configurator

### Viewpoint Maintenance

Viewpoint Maintenance provides tools that will create reports on the operating status of the relay, simplify the steps to download fault and event data, and reduce the work required for cyber-security compliance audits. Tools available in Viewpoint Maintenance include:

- Settings Security Audit Report
- Device Health Report
- Single Click Fault Data Retrieval

### EnerVista™ Integrator

EnerVista™ Integrator is a toolkit that allows seamless integration of Multilin devices into new or existing automation systems. Included in EnerVista™ Integrator:

- OPC/DDE Server
- Multilin Drivers
- Automatic Event Retrieval
- Automatic Waveform Retrieval

### User Interface

The T60 front panel provides extensive local HMI capabilities. The local display is used for monitoring, status messaging, fault diagnosis, and device configuration. User configurable messages that combine text with live data, can be displayed when user-defined conditions are met.



Typical Wiring

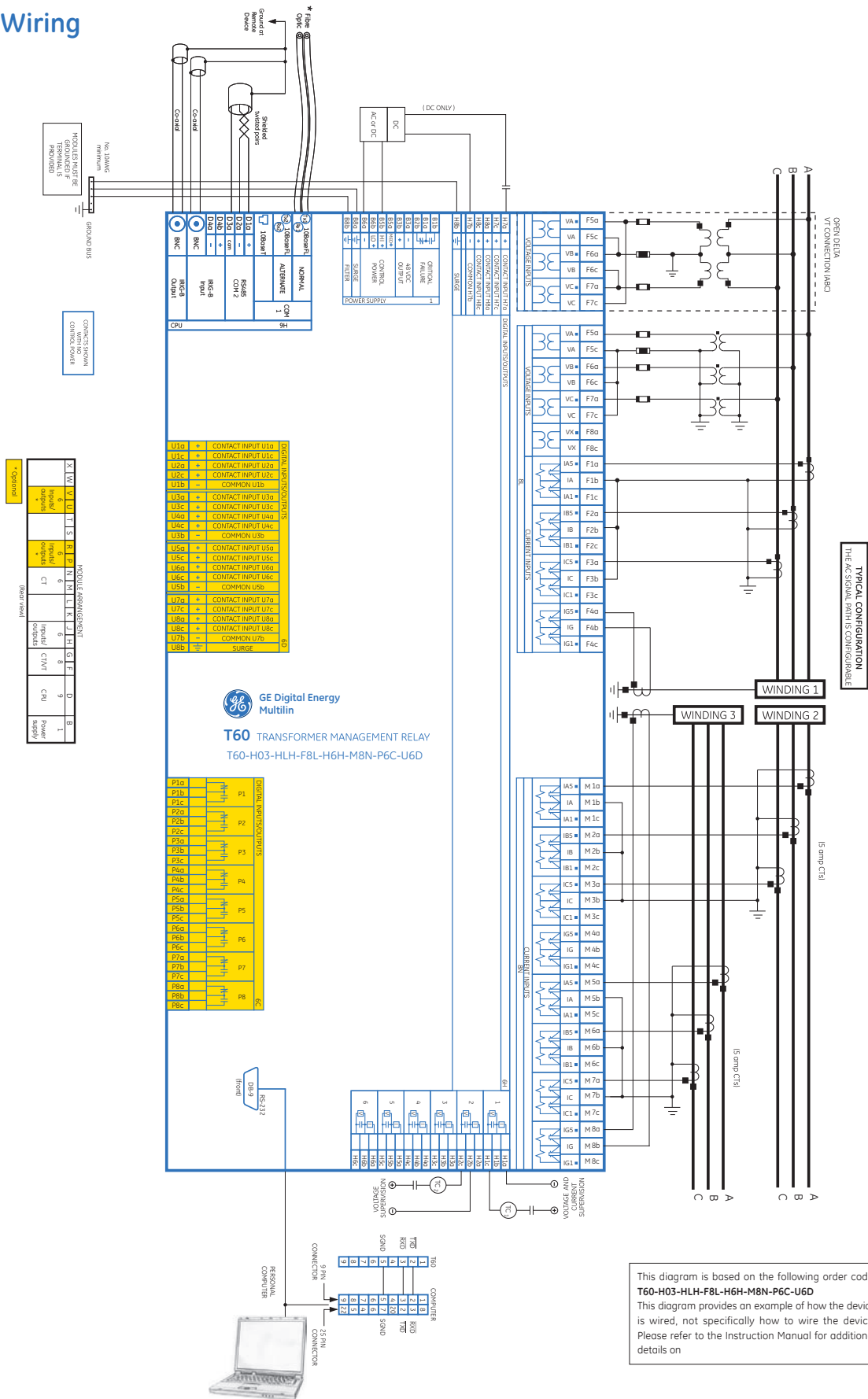

This diagram is based on the following order code: **T60-H03-HLH-F8L-H6H-M8N-P6C-U6D**  
This diagram provides an example of how the device is wired, not specifically how to wire the device. Please refer to the Instruction Manual for additional details on

